

**This camera manual library is for reference and historical purposes, all rights reserved.**

**This page is copyright by mike@butkus.org M. Butkus, N.J.**

**This page may not be sold or distributed without the expressed  
permission of the producer**

**I have no connection with any camera company**

**If you find this manual useful, how about a donation of \$3 to: M. Butkus, 29 Lake Ave., High Bridge, NJ 08829-1701 and send your E-mail address too so I can thank you. Most other places would charge you \$7.50 for a electronic copy or \$18.00 for a hard to read Xerox copy. These donations allow me to continue to buy new manuals and maintain these pages. It'll make you feel better, won't it?**

**If you use Pay Pal, use the link below. Use the above address for a check, M.O. or cash. Use the E-mail of butkusmi@ptd.net for PayPal.**



[back to my "Orphancameras" manuals /flash and light meter site](#)

Only one "donation" needed per manual, not per multiple section of a manual !

The large manuals are split only for easy download size.

Canon SURE SHOT

ZOOM S

SURE SHOT

Caption ZOOM



E

INSTRUCTIONS  
English Edition

F

MODE D'EMPLOI  
Edition française

S

INSTRUCCIONES  
Edición española

# NOMENCLATURE

① Date Button

② Caption Imprint Selector ★

③ Self-Timer Button

④ Shutter Button

⑤ Autofocus Windows

⑥ Viewfinder Window

⑦ Metering Window

⑧ Remote Control Window ★

⑨ AF Light Projector

⑩ Red Lamp (Self-timer/  
Remote Control Indicator)

⑪ Set Button ★

⑫ Select Button ★

⑬ Frame Counter

⑭ Display Panel

⑮ Film Rewind Button

⑯ Flash Mode Selector

⑰ Remote Control Release  
Button (Red) ★

⑱ Flash

⑲ TELE Button

⑳ WIDE Button

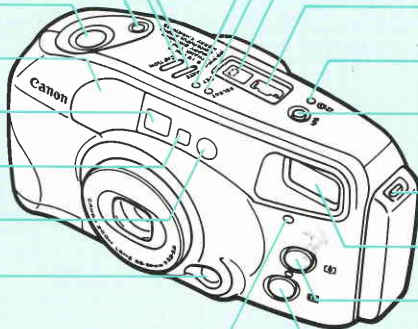

★ = Sure Shot Caption Zoom only

②① Remote Controller ★

②② Control Button (Gray) ★

②③ Signal Transmitter ★

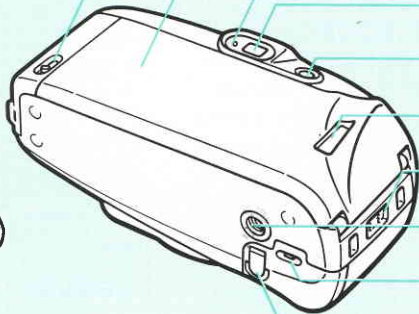

②④ Back Cover Latch

②⑤ Back Cover

②⑥ Green Lamp (AF in-focus/  
Too-close warning/  
Focus lock completion)

②⑦ Viewfinder

②⑧ Red Button (ON/OFF)

②⑨ Film Check Window

③⑩ Strap Fixture

③① Tripod Socket

③② Battery Cover Slot

③③ Tilt Stand

# **NOMENCLATURE**

- ① Bouton de date
- ② Sélecteur d'impression de message (Sure Shot Caption Zoom seulement)
- ③ Retardateur
- ④ Déclencheur
- ⑤ Fenêtres autofocus
- ⑥ Fenêtre du viseur
- ⑦ Fenêtre posemètre
- ⑧ Fenêtre de télécommande (Sure Shot Caption Zoom seulement)
- ⑨ Emetteur de lumière AF
- ⑩ Témoin rouge (retardateur/télécommande)
- ⑪ Bouton de réglage (Sure Shot Caption Zoom seulement)
- ⑫ Bouton de sélection (Sure Shot Caption Zoom seulement)
- ⑬ Compteur de vues
- ⑭ Ecran LCD
- ⑮ Rembobinage du film
- ⑯ Sélecteur du mode de flash
- ⑰ Verrou de télécommande (rouge) (Sure Shot Caption Zoom seulement)
- ⑱ Flash
- ⑲ Bouton TELE
- ⑳ Bouton WIDE
- ㉑ Télécommande (Sure Shot Caption Zoom seulement)
- ㉒ Bouton de commande (gris) (Sure Shot Caption Zoom seulement)
- ㉓ Emetteur de signal (Sure Shot Caption Zoom seulement)
- ㉔ Verrou du dos
- ㉕ Dos
- ㉖ Témoin vert (mise au point AF/avertissement de trop près/mise au point Single Spot)
- ㉗ Viseur
- ㉘ Bouton rouge (en circuit/hors circuit)
- ㉙ Fenêtre de contrôle de chargement du film
- ㉚ Attache de courroie
- ㉛ Filtage pour trépied
- ㉜ Encoche du couvercle de pile
- ㉝ Dispositif d'inclinaison

# Table of Contents

|  |           |   |           |
|--|-----------|---|-----------|
| Handling Precautions . . . . .                                       | 13        | <b>III. Other Operations . . . . .</b>                                    | <b>53</b> |
| <b>I. Shooting Preparations . . . . .</b>                            | <b>17</b> | 1. Flash-on Mode . . . . .  | 53        |
| 1. Neckstrap . . . . .   | 17        | 2. Flash-off Mode . . . . .   | 55        |
| 2. Checking the Battery . . . . .                                    | 19        | 3. Remote Control Shooting (Sure Shot<br>Caption Zoom only) . . . . .     | 57        |
| 3. Holding the Camera . . . . .                                      | 23        | 4. Caption and Date Imprinting (Sure Shot<br>Caption Zoom only) . . . . . | 61        |
| 4. Shutter Button Action . . . . .                                   | 25        | <b>Battery Replacement . . . . .</b>                                      | <b>73</b> |
| 5. Checking the Display Panel Information . . . . .                  | 27        | <b>Specifications . . . . .</b>   | <b>74</b> |
| 6. Loading the Film . . . . .  | 29        |   |           |
| 7. Automatic Film Rewind . . . . .                                   | 33        |   |           |
| Mid-roll Rewind . . . . .  | 35        |   |           |
| <b>II. Basic Picture Taking Operation . . . . .</b>                  | <b>35</b> |   |           |
| 1. Auto Mode . . . . .   | 35        |   |           |
| 2. Zoom Operation . . . . .  | 37        |   |           |
| 3. Taking Pictures in Auto Mode . . . . .                            | 39        |   |           |
| Shooting Distance Range for Automatic<br>Flash Photography . . . . . | 41        |   |           |
| Green Lamp . . . . .   | 43        |   |           |
| Close-up Shooting . . . . .  | 43        |   |           |
| Single Spot Focusing [Focus Lock] . . . . .                          | 45        |   |           |
| 4. Self-timer Photography . . . . .                                  | 49        |   |           |

## ! Handling Precautions

- 1) This camera is not resistant to water, and should not be used outdoors if snowing. If accidentally dropped in water, contact an authorized Canon service facility. Keep the camera out of salt spray, and excessive humidity. If used at the beach, clean it thoroughly afterward with a dry cloth.
- 2) Store the camera in a cool, dry, dust-free place. Be sure to keep the camera out of direct sunlight, and away from "hot spots" such as the trunk or rear window shelf of a car. Avoid places where moth balls are used and in excessive humidity, use a desiccant.
- 3) Do not attempt to disassemble the camera yourself, due to the high-voltage circuitry inside.
- 4) The battery may explode or cause burns if disassembled, recharged, shorted, exposed to high temperatures, or disposed of in fire.
- 5) Use a blower brush to remove dust and sand from the lens and inside the camera. Do not apply any fluids to the lens or body. Take it to a Canon service facility for more cleaning if necessary.
- 6) Film passing through X-ray examinations at airports may be exposed and ruined even when loaded in the camera. Request a hand checked inspection to avoid damage.
- 7) Color reproduction may be adversely affected if film is left in the camera for a long time. Always develop exposed film promptly.

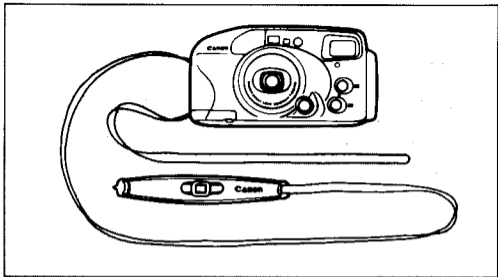

## I. Shooting Preparations

### 1. Neckstrap

- 1) Attach the neckstrap to the fixtures as illustrated.

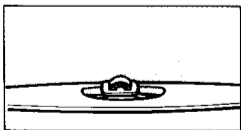
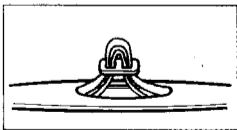
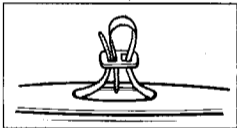



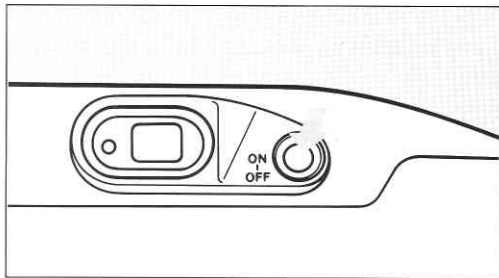



## 2. Checking the Battery

A lithium battery pack (2CR5, 6V) is installed at assembly.

- If a battery has not been included, see p. 73. Check the battery to ensure readiness before shooting.

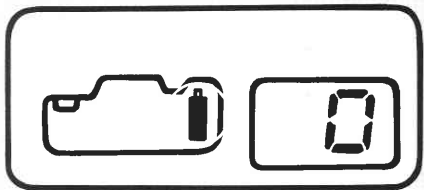
1) Press the red on/off button.



2) The battery power is sufficient if the battery check symbol, “” appears in the display panel.

If “” blinks, have a new battery handy.

If “” does not appear, replace with a new battery.

*Shooting Capacity:* approx. 35 rolls of 24-exp. film with 50% flash use.

(Data based on Canon's Standard Test Method)

- When you intend to take many pictures, ie. trip or wedding, be sure to take a spare battery with you.
- When the camera is not in use, close the lens cover to protect the lens and prevent accidental exposure.



- 1) Put the neckstrap around your neck and hold the camera firmly.
  - 2) Keep your left elbow close to your body.
  - 3) Lightly hold the camera against your nose and look into the viewfinder.
  - 4) Spread your feet about shoulder width for a steady, natural stance.
- Be sure not to block the lens, autofocus windows exposure metering windows, or flash head with your fingers or hair.
  - Be sure not to touch the lens barrel during zooming.

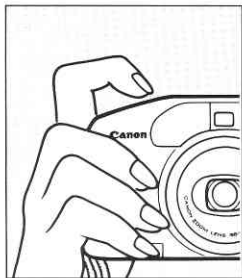
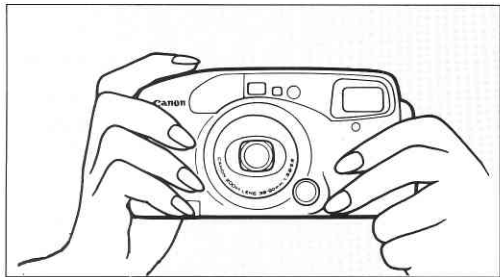

The shutter button activates two functions depending on the amount of the pressure applied.

- 1) Press *halfway* for automatic focus and exposure metering. When the subject is in focus, the green lamp symbol lights up.
- 2) Press *completely* to take the picture.

- The shutter cannot be pressed completely if the subject is not in focus.
- Shutter button action plays an important part in taking sharp pictures. A quick stroke with the tip of your finger or fingernail may cause unnecessary camera movement called "camera shake". Press the shutter button gently.



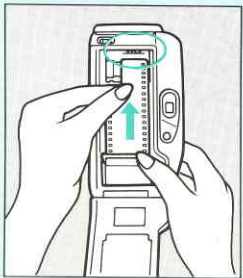
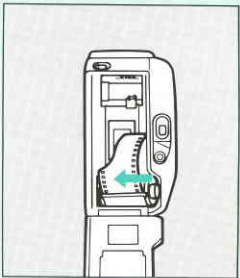
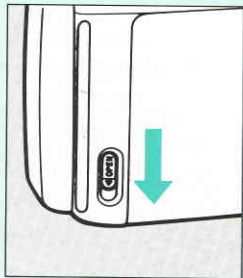
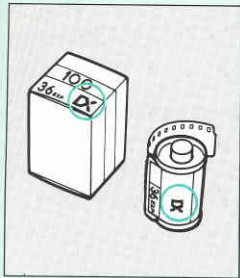

- After about five years, the display panel may become hard to read. Take the camera to the nearest Canon service facility for the replacement of the liquid crystal. Replacement will be at owner's expense.

## 6. Loading the Film

Use only DX-coded film whenever possible. The camera automatically sets the film speed. (ISO 50-3200 according to the DX code standard)

- 1) Slide the back cover latch down to open the back cover.
- 2) Insert the flat end of the film cartridge in first.
- 3) Carefully pull the film tip across just until it reaches the white line marked "FILM".

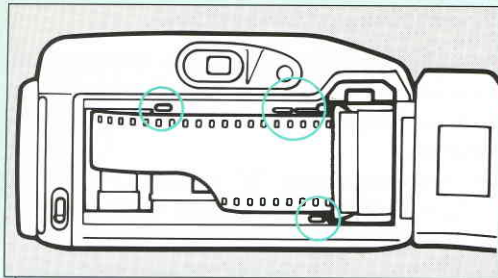

4) Make sure that the film lies flat and close the back cover. The camera advances the film automatically and stops when "1" appears in the frame counter.

- If the film does not advance correctly, three indicators will blink in the display panel to warn you that the film needs to be reloaded. The three indicators are, the frame counter, the film transport bars "■", and the back cover indicator "▲".
- If non DX-coded film is used, the film speed will be set to ISO 100. The film does not load automatically, press the shutter button until "1" appears in the frame counter.
- For slide film, use only ISO 50, 100, 200, 400, 800, 1600, or 3200.

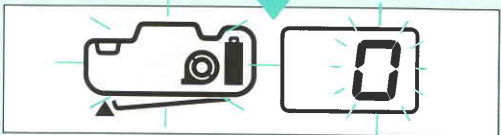
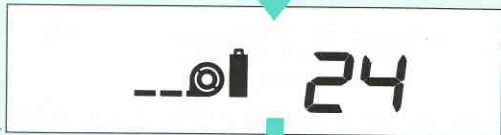
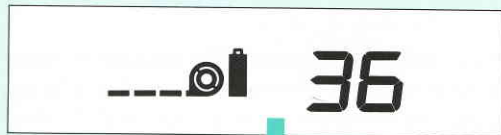

## 7. Automatic Film Rewind

The film automatically rewinds at the end of the roll. During rewind, the frame counter counts in descending order. Film rewind stops automatically when the film has been completely rewound.

- 1) Make sure that "0" appears and "⊙" and "▲" are blinking in the display panel.
- 2) Open the back cover and remove the film cartridge.

- Color reproduction may be adversely affected if film is left in the camera for a long time. Always develop exposed film promptly.



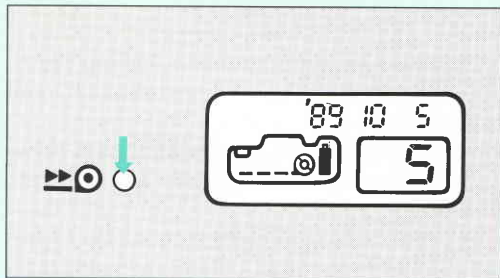

## **Mid-roll Rewind**

Press the film rewind button on the top of the camera to rewind before the end of the roll. Use the small projection on the neckstrap pad.

## **II. Basic Picture Taking Operation**

### **1. Auto Mode**

Each time the red on/off button is pressed, the camera is automatically set to this mode (No display symbol appears). The flash fires automatically in low-light or backlit conditions.

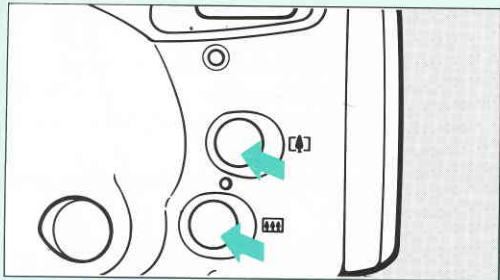

## 2. Zoom Operation

Look through the viewfinder and press the *WIDE* button or the *TELE* button. Compose the picture as you like, using the power zoom. A wide (38 mm) angle-of-view is ideal for landscapes, group pictures, and when featuring an attractive background. With the tele (60 mm), you can take better portraits by bringing the subject closer and eliminating unnecessary elements in the background.



38 mm



60 mm

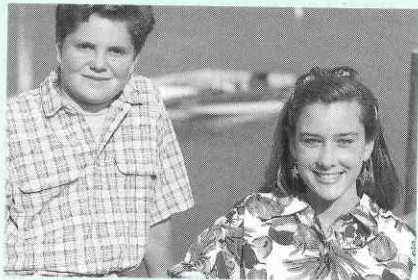

### 3. Taking Pictures in Auto Mode

- 1) Look into the viewfinder and compose the picture.
- 2) Press the shutter button halfway to focus the subject. When the subject is in focus, the green lamp lights up.
- 3) Gently press the shutter button completely to take the picture.

- Keep at least 2 ft/0.6 m away from the subject for sharp focus.
- In low-light or backlit conditions, flash fires automatically.
- The subject's eyes may appear red in flash photos due to the light reflected from the retina. To minimize this, have the subject avoid looking directly at the camera.



(Using color print film)

For proper flash coverage, be sure to stay within range of the film in use.

|           | <b>WIDE (38 mm)</b>         | <b>TELE (60 mm)</b>         |
|-----------|-----------------------------|-----------------------------|
| ISO 100   | 2.0-14.4 ft<br>(0.6-4.4 m)  | 2.0-9.8 ft<br>(0.6-3.0 m)   |
| ISO 200   | 2.0-19.6 ft<br>(0.6-6.0 m)  | 2.0-13.7 ft<br>(0.6-4.2 m)  |
| ISO 400   | 2.0-28.2 ft<br>(0.6-8.6 m)  | 2.0-19.6 ft<br>(0.6- 6.0 m) |
| ISO 1000* | 2.0-39.3 ft<br>(0.6-12.0 m) | 2.0-27.5 ft<br>(0.6-8.4 m)  |
| ISO 1600  | 2.3-47.8 ft<br>(0.7-14.6 m) | 2.0-39.3 ft<br>(0.6-12.0 m) |
| ISO 3200  | 3.3-47.8 ft<br>(1.0-14.6 m) | 2.6-47.8 ft<br>(0.8-14.6 m) |

\*Based on conversion of ISO 800 film.

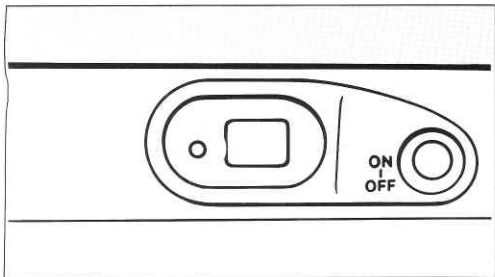

The green lamp serves an important role in relaying information about shooting conditions. Please be aware of these conditions.

- *Green Lamp Conditions*

1. Lights up—focus is sharp.
2. Blinks slowly (4 times/sec)—focus is not sharp; subject is too close.  
(shooting distance range: 2.0-3.3 ft/0.6-1.0 m)
3. Blinks rapidly (16 times/sec)—confirms single spot focusing completion or that the flash is fully charged. See p. 45.

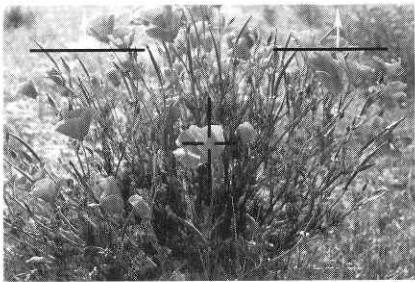

- *Close-up shooting*

When taking a picture from up close, 2.0-3.3 ft (0.6-1m) from the camera, be sure to place the subject below the parallax correction mark.



Thanks to the Evaluative Focusing System, there are few difficult subjects for the camera to focus. However, when shooting a subject extremely off-center, exceptionally small with strong reflection, or with very low contrast, use single spot focusing and the focus lock function.

- 1) First, put the focus mark on the intended subject, and press the shutter button halfway.

2)

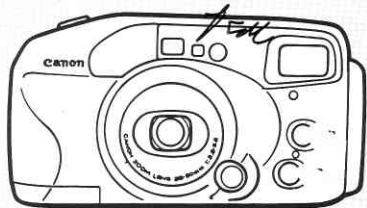

- 2) Press the TELE and WIDE buttons together once while pressing the shutter button halfway. Make sure that the green lamp blinks rapidly.
- 3) Reframe the picture as desired while continuing to press the shutter button halfway. Finally press the shutter button completely to take the picture.

- Single spot focusing is also necessary when shooting a subject through a window, i.e., a car or bus.
- When using focus lock, be sure that the distance between you and the subject does not change.
- Focus lock clears when you remove your finger from the shutter button.

3)



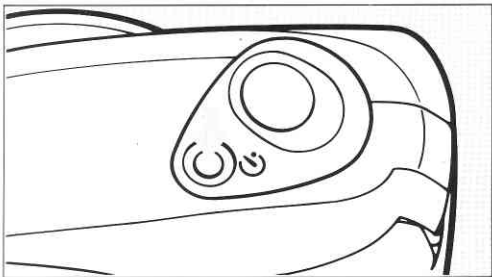

The self-timer function delays shutter release for 10 seconds to include yourself in the picture.

- 1) Compose the picture and press the self-timer button. Be sure that the green lamp lights up.
- 2) The red lamp below the flash starts blinking slowly and then rapidly two seconds before the picture is taken.

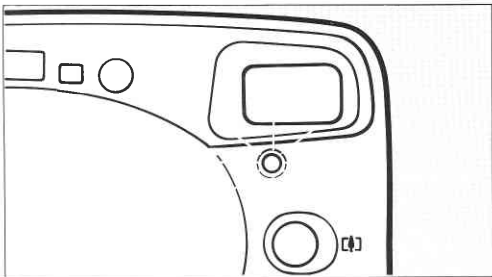





- To cancel the self-timer before the 10-second delay finishes, repress the self-timer button or the red on/off button.
- Use the tilt stand for better camera position as illustrated.

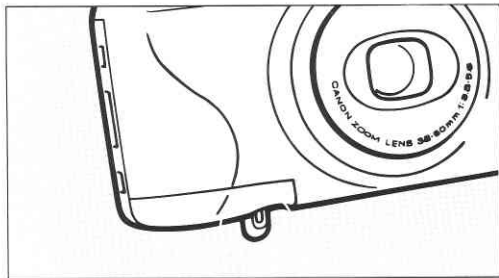

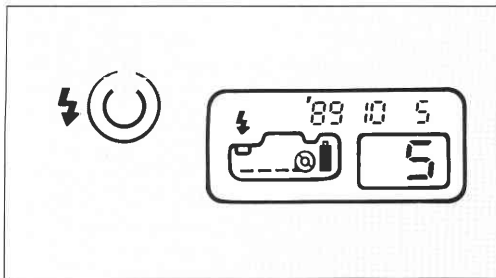

Press the flash mode selector to set the flash-on mode or the flash-off mode.

The flash is not solely for dark conditions. For example, in daylight, use the flash to fill the shadow of a backlit subject such as a person in front of a bright window, or backed by the sun.



- The flash-on mode shooting distance range is exactly the same as the auto-flash mode, see p. 41. Stay within this range for best results.
- The shutter button cannot be pressed until the flash is fully charged. The amount of time required to wait between flash pictures is approx. 2.5 seconds.

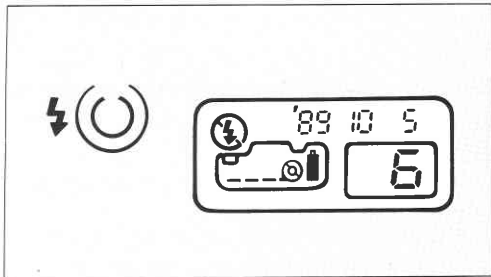

Set the flash-off mode to cancel the flash when you want to take pictures of sunsets or are in places where flash use is not allowed, i.e. theaters, museums.

- Pictures taken in this mode are susceptible to camera shake. To minimize this, hold the camera steady by leaning against a tree, wall, or table. A tripod will also help to keep the camera steady.

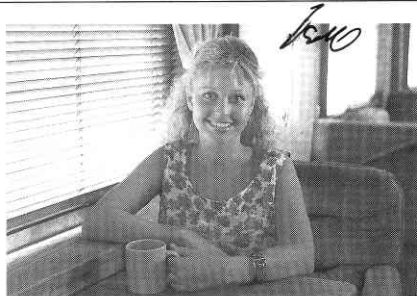

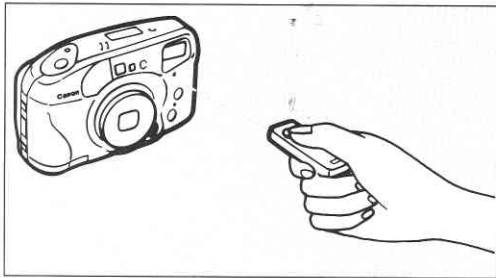
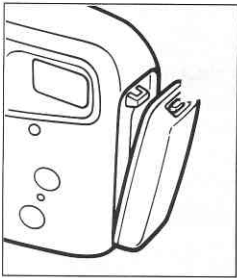

The remote controller gives you the freedom to take pictures without pressing the shutter button. This allows you to set up the scene, and get in the picture, too.

- 1) Remove the controller by pressing the red release button.
  - The red lamp starts blinking indicating that the controller is detached from the camera. (Blinks only when the lens cover is open.)
- 2) Place the camera on a steady surface, such as a table, or use a tripod.
- 3) Look into the viewfinder and compose the picture.
- 4) Aim the controller directly toward the front of the camera, not more than 16.4 ft/5 m away.

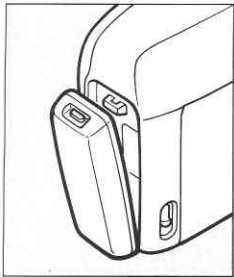

5) Press the grey control button to take the picture. There is a two-second delay to conceal the controller before the picture is taken. During this time, the red lamp blinks faster.

- To replace the controller, always insert the lower end first, and make sure it locks with a click.
- The controller's circuitry requires that a picture be taken within eight minutes after being detached from the camera. After this period, replace the controller and remove it again.
- When the subject is extremely backlit, e.g. with the sun behind it, the controller may not function.

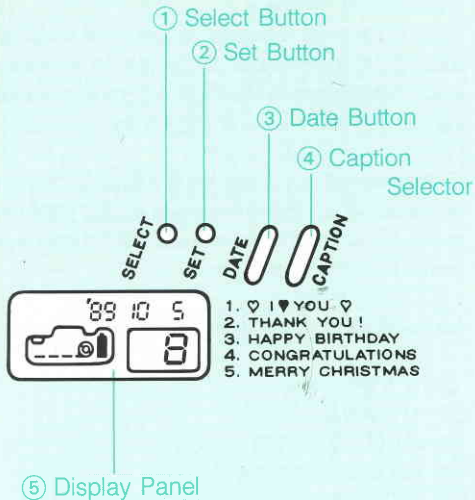

## 4. Caption and Date Imprinting (Sure Shot Caption Zoom Only)

### Caption Imprint Function

Make the occasion more memorable by imprinting the date or a caption for a special touch. There are five captions and four date formats, however they cannot be used together.

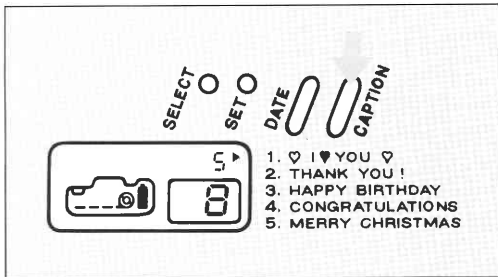

Select the desired caption by pressing the caption selector. Be sure the number for the desired caption appears in the display panel. The caption is imprinted for one exposure.

The caption is imprinted on the lower-right corner in orange when using color film. **A dark background is best** for clear caption imprinting results.

The display changes in the order below:

- 1▶ (♡ I ♡ YOU ♡)
- 2▶ (THANK YOU!)
- 3▶ (HAPPY BIRTHDAY)
- 4▶ (CONGRATULATIONS)
- 5▶ (MERRY CHRISTMAS)

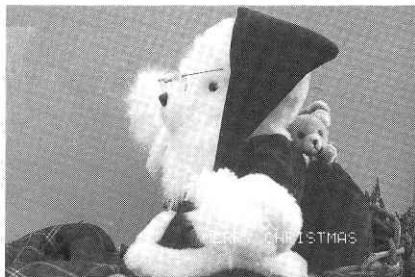

- Simulated caption
- Message simulé
- Mensaje simulado



- Press the date selector to **cancel caption imprinting**. The hyphens will *not* appear on the picture.
- The caption and date imprint function is designed to work only on film cartridges with 12, 24, or 36 exposures. For film cartridges with more than these (ie. 18 or 27), do not imprint the date or caption on the last frame.

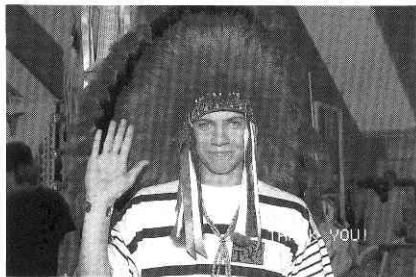

- Simulated caption
- Mensaje simulado
- Message simulé





- Simulated date
- Date simulée
- Fecha simulada

The Sure Shot *Caption Zoom* imprints the date on pictures automatically to make it easy to recall a special date or time. A built-in calendar programmed through December 31, 2019 automatically compensates for long and short months and leap years.

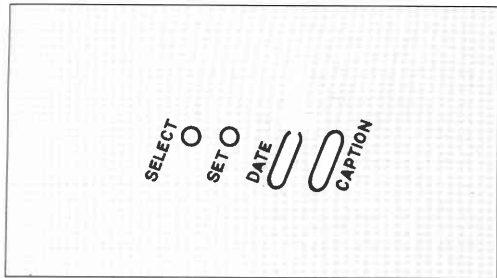

Each time the date button is pressed, the format changes in the following order:

Year/Month/Day  
Month/Day/Year  
Day/Month/Year  
Day/Hour/Minute  
-- -- (No Imprint)

The format appearing in the display panel will be imprinted on the lower-right corner in orange when using color film. A dark background is best for clear date imprinting results.

- **If no date imprint is desired**, make sure the hyphens appear in the display panel. They will not appear on the photo.

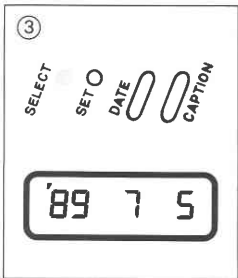
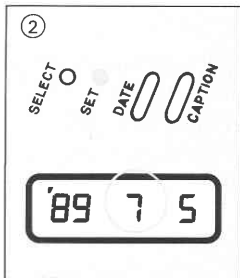
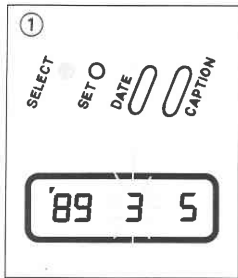

## 2. Setting the Date and Time

Each time the select button is pressed, the digits blink in the order of: year, month and day regardless of the format.

- 1) Press the select button for the desired position.
- 2) Press the set button to enter the desired number.
  - Hold the set button down to increase the number quickly.
- 3) Press the select button again to complete the setting.

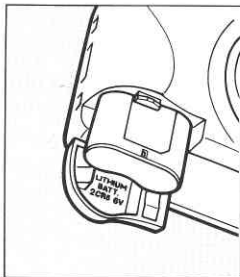
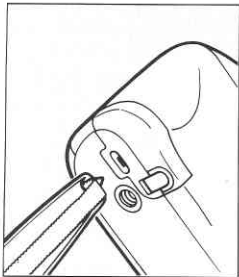

If the battery check indicator “  ” does not appear in the display panel, replace the battery as follows:

- 1) Insert the small projection on the neckstrap into the recessed slot on the bottom of the camera.
- 2) Press down and slide the cover toward the front of the camera to open. The cover cannot be removed from the camera.
- 3) Take the battery out, and insert a new 2CR5 6-volt lithium battery. Close the cover securely.
  - With the Sure Shot Zoom Caption Date the date back display returns to “'87 1 1” Reset the date.

## Specifications

### General

**Type:** 35mm lens-shutter camera with autofocus and built-in power zoom lens

**Lens:** Spectra-coated, 38-60mm f/3.8-5.6

**Lens Construction:** 6 elements in 6 groups

**Viewfinder:** Real-image zoom; gives 84% coverage of actual picture area and 0.4 × (WIDE)/0.64 × (TELE) magnification

**Viewfinder Information:** Focus mark and picture frame with parallax correction marks **Next to viewfinder:** Green LED lights steadily on evaluative AF completion, blinks at 4 Hz when the subject is too close and blinks at 16 Hz on flash charge completion or on normal AF completion

**Shutter:** Programmed shutter; also serves as diaphragm.

### Autofocus

**AF Control:** Evaluative Active System

**Focusing Range:** 2 ft (60cm)-infinity

### Exposure Control

**AE Control:** 3-zone metering, programmed system

**Metering Range:** (at ISO 100)

**Auto/Flash-on mode:** WIDE: EV 9.25-17/TELE: EV 11-18.5

**Non-flash mode:** WIDE: EV 2.85-17/TELE: EV 4-18.5

**Exposure Compensation:** Automatic when required by +2 steps.

### Film Handling

**Film Speed Setting:** ISO 50-3200; automatically set in one-step increments according to DX code.

**Film Loading/Wind/Rewind:** Automatic. Mid-roll rewind possible.

### Flash

**Guide Number** (at ISO 100): 36 ft/11 m

**Recycling Time:** Approx. 2.5 sec.

**Flash Coupling Range** (at ISO 100): *Wide:* 2-14.4 ft (0.6-4.4 m); *Tele:* 2-9.8 ft (0.6-3.0 m)

**Flash Firing:** Automatic when required or at user selection

*Other*

**Self-Timer:** Provided with a 10-sec. delay

*Power Source*

**Battery:** One, 6V lithium battery (2CR5)

**Shooting Capacity:** 35 rolls of 24-exp. film with 50% flash use

**Caption Imprint:**

(Sure Shot Caption Zoom): Five captions available

**Date Imprint:** (Sure Shot Caption Zoom): Four formats available with automatic calendar and clock

**Date and Caption Imprint Function:** Powered by body battery

**Remote Control:** (Sure Shot Caption Zoom): Detachable controller with two-sec. delay shutter release.

**Operating range:** approx. 16.4 ft/5.0 m from directly in front, approx. 1.4 ft/3.5 m at 25°. *Power source:* Two 3V lithium batteries (CR 1220); Battery life: about 20,000 transmissions. Replacement is at owner's expense at an authorized Canon service facility.

*Dimensions*

**Size:** Sure Shot Zoom S: 5-9/16" (W) x 3" (H) x 2-3/16" (D) (141 x 76.8 x 55.9mm)

Sure Shot *Caption Zoom*: 5-13/16" (W) x 3" (H) x 2-3/16" (D) (147.9 x 76.8 x 55.9mm)

**Weight:** Sure Shot Zoom S: 13.6 oz. (385 g) without battery 15 oz. (425 g) with battery

Sure Shot *Caption Zoom*: 13.9 oz. (395 g) without battery 15.4 oz. (435 g) with battery

All data are based on Canon's Standard Test Method. Subject to change without notice.

This digital apparatus does not exceed the Class B limits for radio noise emissions from digital apparatus set out in the Radio Interference Regulations of the Canadian Department of Communications.